

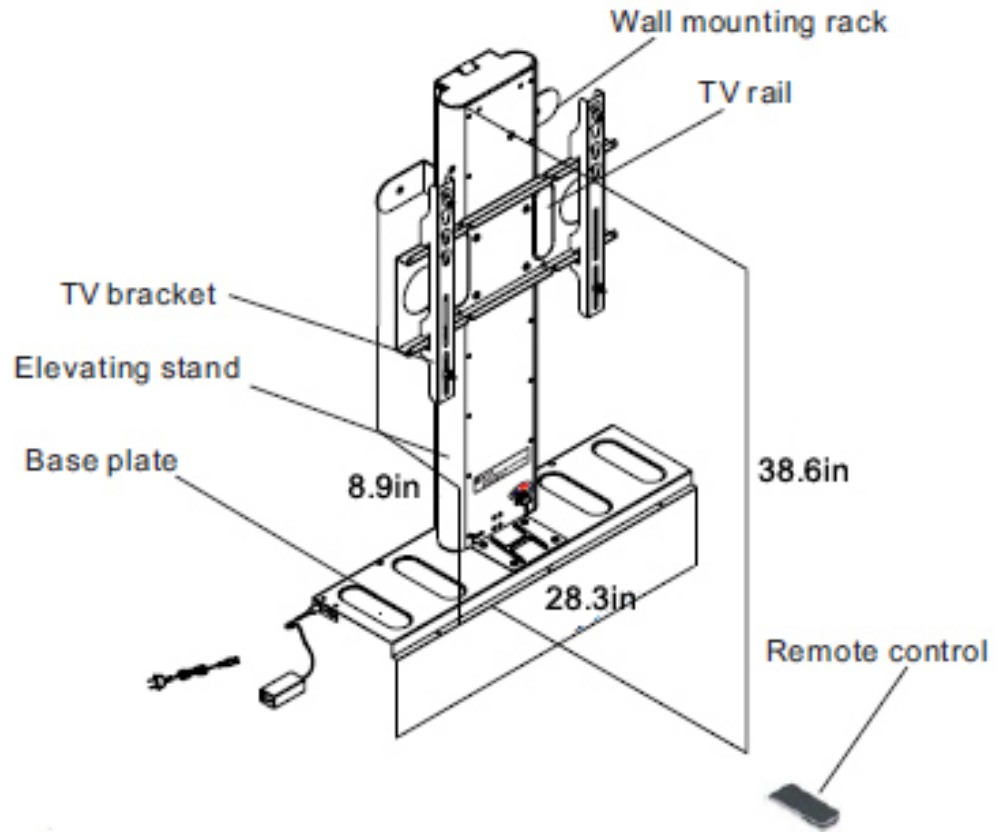













## 1. SPECIFICATION

### 1-1. DIMENSION

Length: 28.3 in  
Height: 38.6 in  
Width: 8.9 in



### 1-2. INSTALLATION PARTS:

①	2pcs	②	2pcs	③	2pcs	④	2pcs
	Sink head screw M5/M6/M8 (mm)		Tab M5/M6/M8(mm)		Round head screw M5/M6/M8 (mm)		Washer ø16*6.2*T1.5/ ø16*8.4*T1.6(mm)
⑤	5pcs	⑥	5pcs	⑦	2pcs	⑧	20pcs
	Plastic wall plug Φ10*47mm		M6*50mm Self-tapping screw		Pad M5/M6/M8(mm)		m6*10mm Screw
⑨	2pcs	⑩	2pcs	⑪	1pcs		
	M8*70mm Expansion screw		Round head screw M6*35(mm)		Remote control		

Notice 1: Use originals only, any other unapproved components may result in the falling off of TV and this bracket.

Notice 2: Check all the parts included with shown in the manual. If parts are missed or damaged, do not use it and please return to your local distributor.

### 1.3 ASSEMBLY TOOLS (NOT INCLUDED)

				
Hammer	Electric drill	Spanner	Cross screwdriver	Pencil

## 2. ELECTRIC SPECIFICATION

### 2-1. INPUT VOLTAGE/CURRENT/FREQUENCY, OUTPUT CURRENT

- A. Input voltage/Current/Frequency: 110-240VAC/< 1.2A/50~60Hz
- B. Output current: DC24V , 3A

### 2-2. MOTOR

Item	Rated Voltage	Current (No load)	Current (Rated load)	Operation Temperature
Motor	DC24V	≤ 0.7 A	≤ 1.8 A	-20 C ~ -50 C

### WARNING:

1. Incorrect installation may result in fall off of TV and this bracket and personal injuries.
2. Wall or floor mounting of this bracket is out of the responsibility of manufacturer shall be carried out by competent persons, or licensed person, with using the attached anchors (Ø10-M8x70) only to ensure the safety.
3. Use this bracket properly, please read the instructions carefully before installation. Keep this guide well for further reference.
4. The user must pay attention to the weight of TV and This product, and only solid wall (the wall must be make up of concrete or brick) can support the weight . Please complied with the installation instruction of LCD/PDP to install them.
5. Do not attach the TV on the bracket before installations.
6. Keep the knob at “Close” position before fully installation, on the other hand do not forget to switch it to “Open” after installation is finished.

### 3. INSTALLATION INSTRUCTION

**3-1.** Firstly, please make sure the wall is even and has a thickness at least 80mm and at the position where you want to mount the TV no any hard materials (such as : reinforcing steel bar , steel block ,etc) and any unstable structures exist. Install elevating stand on the base plate by fastening ® M6X10mm screws, then fix the wall mounting rack and reinforce plate to elevating stand and base plate by ® M6X10mm screws.(see diagram 1)

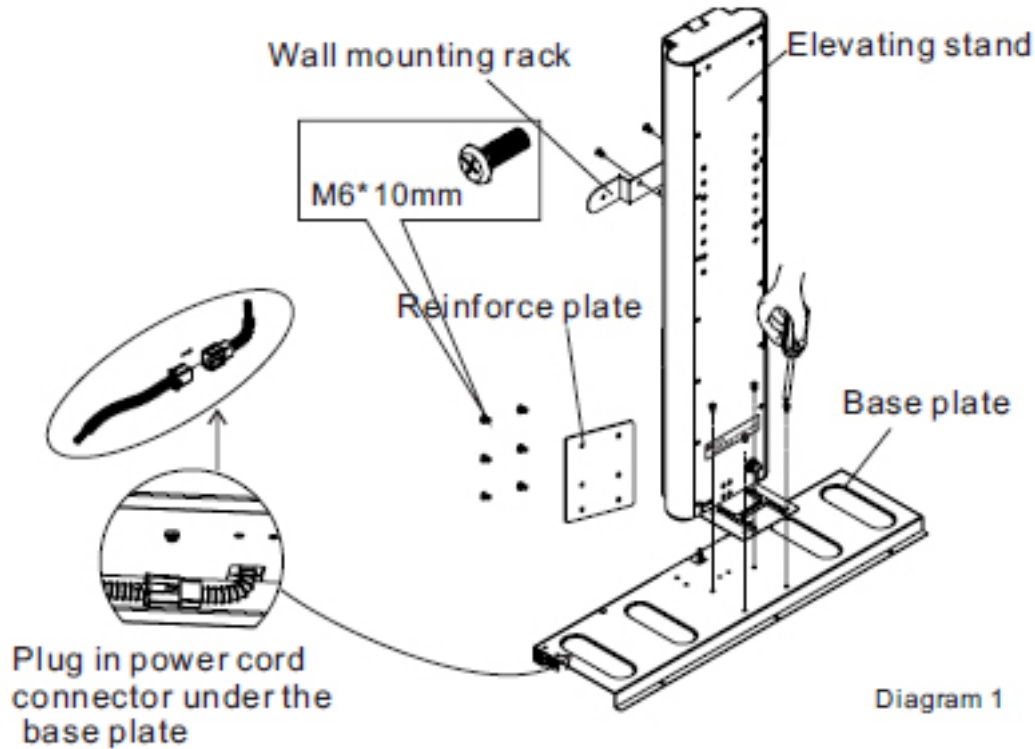

**3-2.** Move the assembled to installation position and mark screw hole locations to be drilled,use electric drill to drill holes on the wall at marked locations to 75mm depth, 10mm and drill holes on the ground at marked locations to 60-70mm depth, 10mm; then put (5) plastic wall plug into the holes(5- 10mm) on the ground. (see diagram2)

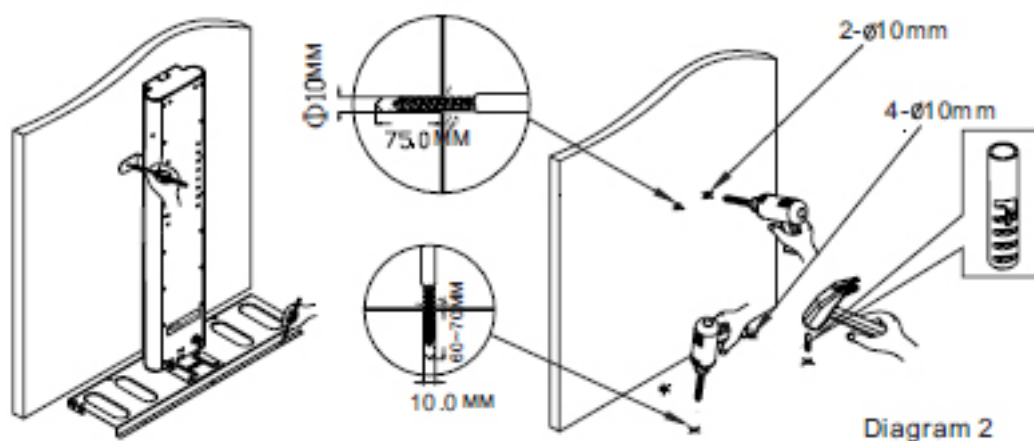

**3-3.** Fasten base plate on the ground by M6X50mm self- tapping screws. (See diagram 3)

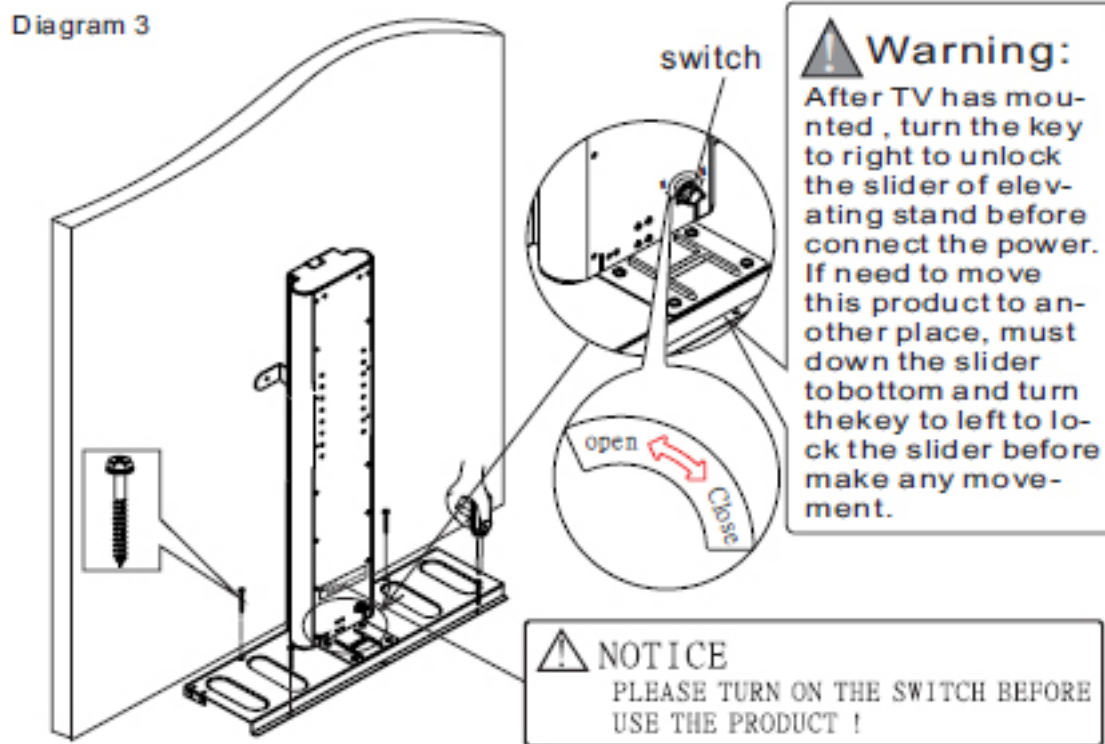

**3-4.** Connect the power supply and turn on the switch, use remote control to rise the elevating stand to the top position, then fix the wall mounting rack to the wall by (9) expansion screws, and connect the base plate and elevating stand by (8) M6X10mm screws. (see diagram 4)

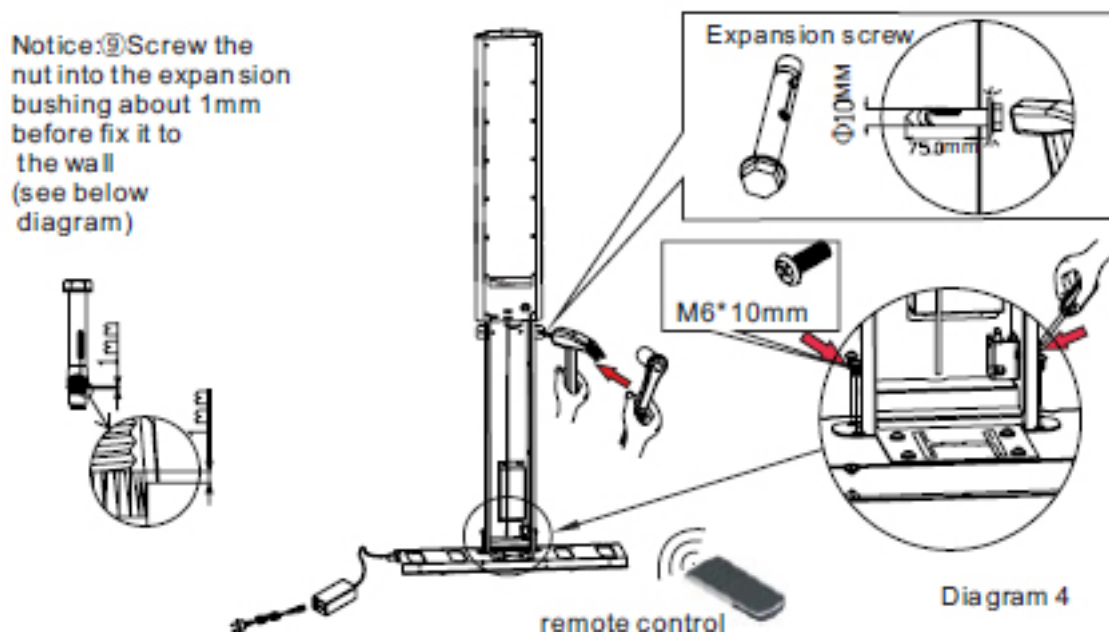

**3-5.** Adjust the elevating stand to the bottom position, turn off the switch, fix the TV rail to elevating stand by (8) M6X10mm screws. (See diagram 5)

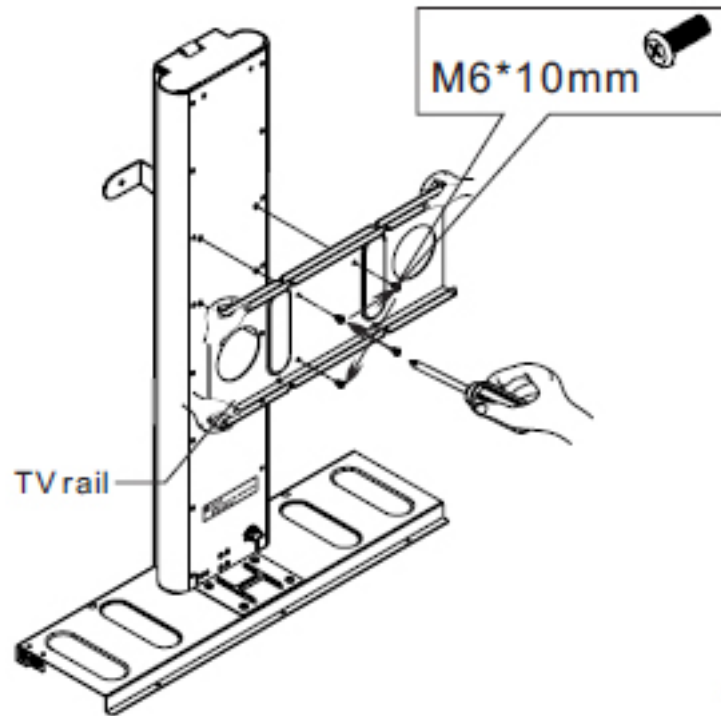

Diagram 5

**3-6.** Screw up (2) tabs on the upper holes of TV back cover by (1) sink head screws, then, hook TV brackets on the tabs. Fasten lower end to TV back cover by screwing up (3) round head screws, (4) washers and (7) pads. (See diagram 6)

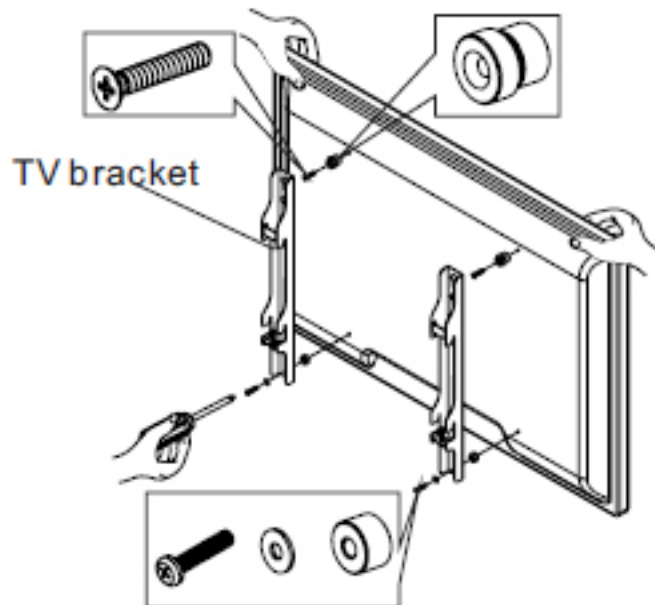

Diagram 6

**3-7.** Hook TV on the TV rail, centerize TV, then screw up the (10) Round head screw M6\*35 screws on TV bracket to fasten up TV tightly. Use the wire saddle to fix the power cord of TV. (see diagram 7)

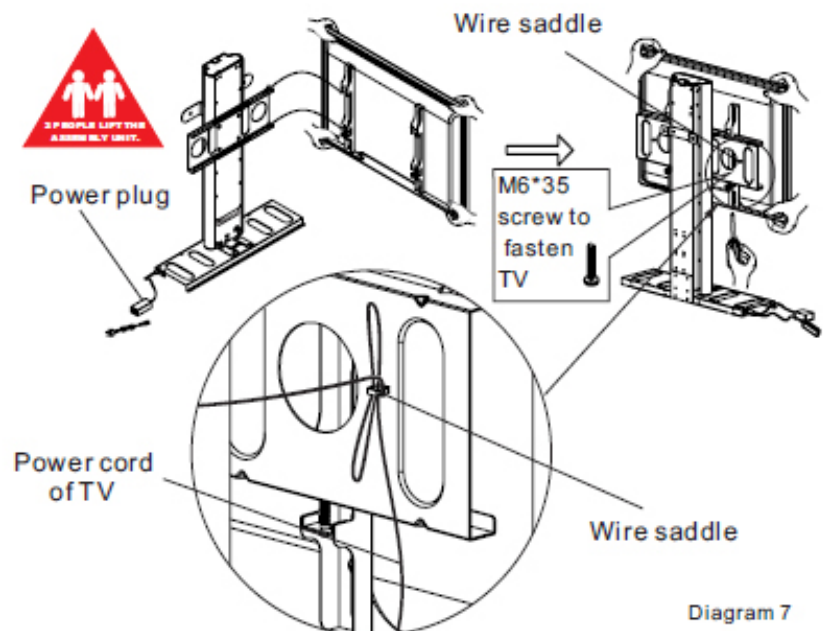

Diagram 7



## 4. OPERATING INSTRUCTION.

**4-1. FUNCTION:** This product has remote control control, they can control elevating stand to move 640mm from up to down. (see diagram 8)

**4-2. REMOTE CONTROL** (See diagram 9):

### 4-2.1. KEY FUNCTION

1. Up : one push to extend elevating stand to the top.
2. Down : one push to back elevating stand to the bottom.
3. Left : hold on to raise elevating stand.
4. Right : hold on to lower elevating stand.

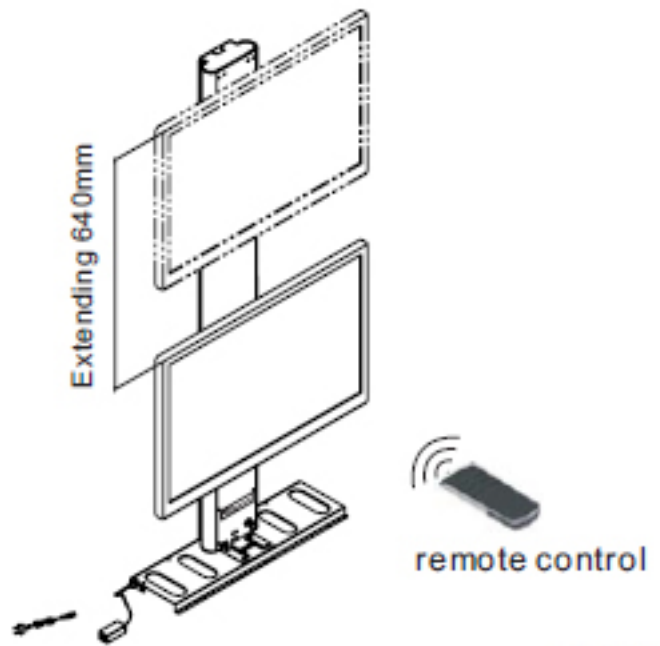

Diagram 8

### 4-2.2. OPERATING INSTRUCTION

1. Aim the LED indicator (on remote control) at TV . The remote range is 3 -10m.
2. Insert one 23A,12V battery in the remote control. If the battery ran out , please open the battery cover and put in new battery.
3. When user press any function key of remote control, the TV bracket with TV will move to the corresponding place ,and will stop when you loosen the key.

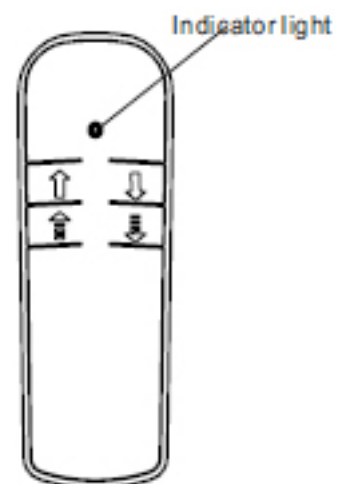

Diagram 9

### 4-2.3. NOTICE

If any remote control of our product was lost or damaged ,you can buy a new remote control and manual control with the same frequency which produce by our company(For the specific operation way, please see the attached user's guide of manual control).

## 5. TECHNICAL PARAMETERS:

Item Model	TV Screen Size (inch)	Cart Dimension	Max Installation Size (inch)	Min Installation Size (inch)	Operating Life (times)	L/R angle ( )	Extending Length(in)	Net Weight (lbs)
NY-13	32~42"	28.3"x 8.9"x38.6"	23.6 x 15.7	7.87 x 7.87	30,000	± 15	25.2	60.63 ±1

## WARNING:

This wall mount is intended for indoor use only with the maximum weights indicated . Use with vier than the maximum weights indicated may result in instability causing possible injury.

## 6. CAUTION:

● Do not connect before fasten the product.



● Make sure wire and plug are good before connecting.





- Do not touch or push the product by hand or other object when it is working. Check carefully to make sure every parts are fastened tightly before use.
- Do not use outdoors unless marked for outdoor use.
- Don't hang other weights on this bracket!

## 7. MAINTENANCE

Unplug the powers of this bracket & FPD before maintenance is engaged in and follow the tructions described in FPD 's manual for daily maintenance of TV & bracket. Do not use corrosive agent or alcohol or chemical cloth to clean!

**8. RELIABILITY** Temperature and humidity condition: -20 C - +50 C, 80%HR

## WARNING:

1. Do not disassemble the product to repair by yourself . Warranty for electricity is void after disassembled.
2. After you installed the apparatus, please check the expansion screws and all fastening devices every 3 months, and please do not use it and contact the local dealer if gets loose, rusty or lost.
3. The drive component of this product is uncontinual drive component. If need to work continually, you must stop 2 hours after working 8 hours!
4. This appliance is not intended for use by persons (including children) with reduced physical, sensory or mental capabilities, or lack of experience and knowledge, unless they have been given supervision or instruction concerning use of the appliance by a person responsible for their safety.
5. Children should be supervised to ensure that they do not play with the appliance.

## HINT OF HOW TO DISPOSE:

- Do not dispose of electrical appliances as unsorted municipal waste, use separate collection facilities.
- Contact your local government for information regarding the collection systems available.
- If electrical appliances are disposed of in landfills or dumps, hazardous substances can leak into the groundwater and get into the food chain, damaging your health and well-being.
- When replacing old appliances with new once, the retailer is legally obligated to take back your old appliance for disposal at least for free of charge.

