



## REMOTE CONTROLLED FLAT PANEL TV BRACKET







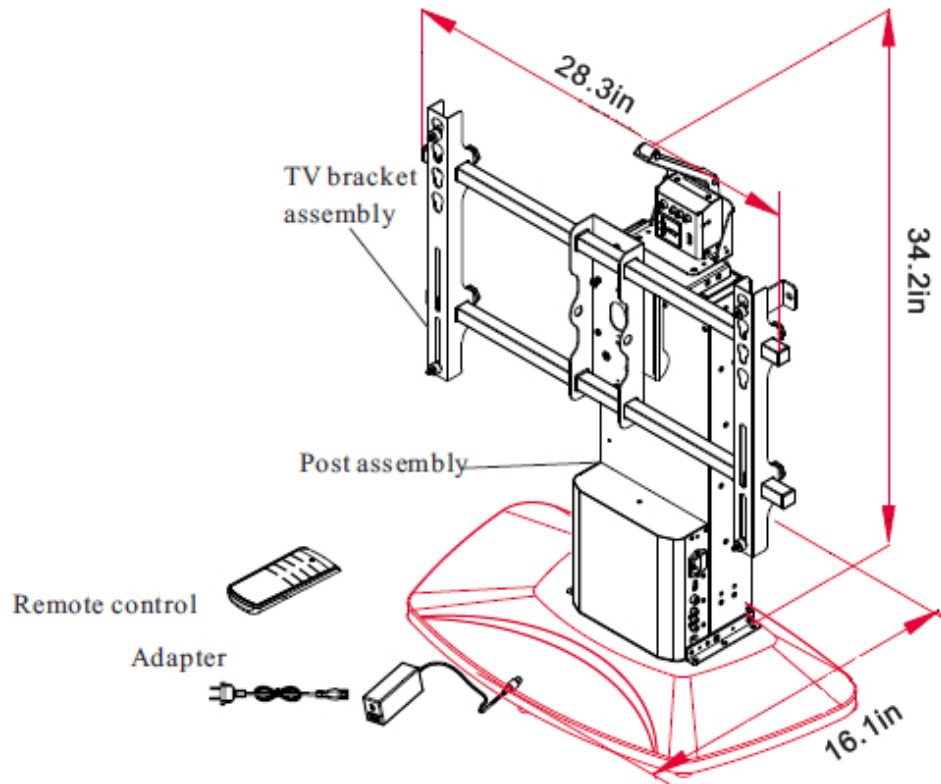



### 1. SPECIFICATION

#### 1-1. DIMENSION

Length: 28.3 in  
Height: 16.1 in  
Width: 34.25 in







#### 1-2. INSTALLATION PARTS:

① 2pcs	② 2pcs	③ 4PCS	④ 6pcs	⑤ 1pc
 Ø10*47mm Nylon plastic plug	 M6*50mm Hexagon flange wood screw	 M6*10mm Cross Panhead screw	 Plastic head screw	 Remote control
⑥ 2pcs	⑦ 2pcs	⑧ 2pcs	⑨ 2pcs	⑩ 2pcs
 M5/M6/M8 Cross Sinkhead screw	 M5/M6/M8 Cross Panhead screw	 Tab	 Pad	 Washer

#### NOTICE:

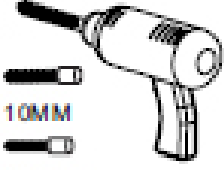
Check all the parts as shown on the manual included. If parts are missed or damaged, do not use it and please return to your local distributor.

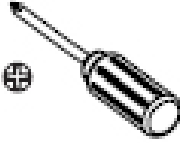
## 1.3 ASSEMBLY TOOLS (NOT INCLUDED)

 <p>Hammer</p>	 <p>10MM 8.5MM Electric drill</p>	 <p>14MM Spanner</p>	 <p>Cross screw driver</p>	 <p>Pencil</p>
--	---	--	---	--

## 2. ELECTRIC SPECIFICATION

### 2-1. POWER SUPPLY SPECIFICATIONS

Use the supplied AC adapter with the following specifications:

Input: 110-240V, 1.2A, 50/60Hz

Output current: DC24V , 3.0A

### 2-2. DEVICE SPECIFICATIONS

DC Input: DC 24V, 3.0 A

AC Input: AC 100 - 250V, 2.0A, 50/60Hz

AC output: AC 100 - 250V, 2.0A, 50/60Hz

### 2-3. MOTOR

Item	Rated Voltage	Current (No load)	Current (Rated load)	Operation Temperature
Motor	DC24V	≤ 0.7 A	≤ 1.8 A	-20 C ~ -50 C

### WARNING:

Correct installation is extremely essential, and falls outside the scope of responsibility of manufacturer. The user must pay attention to the weight of TV and this product, and only solid wall (the wall must be made up of brick, concrete or wood) can support the weight. Please comply with the installation instruction of LCD/PDP to install them.

### 3. INSTALLATION INSTRUCTION

**A.** For installing against the wall, ensure there are not any reinforced steel bar or iron block in the wall and the wall is not soft, make a mark on the wall according to the hole position of support bracket. Drill the hole on the mark depth 50~60mm,  $\varnothing 10\text{mm}$  by electric drill. Take out 2pcs (1)  $\varnothing 10 \times 47\text{mm}$  Nylon plastic plug and insert them into the holes, and fasten the (2)  $M6 \times 50\text{mm}$  Hexagon flange wood screw through the holes of support bracket into the plug by Spanner, ensure that the post assembly can not be moved. (See diagram 1)

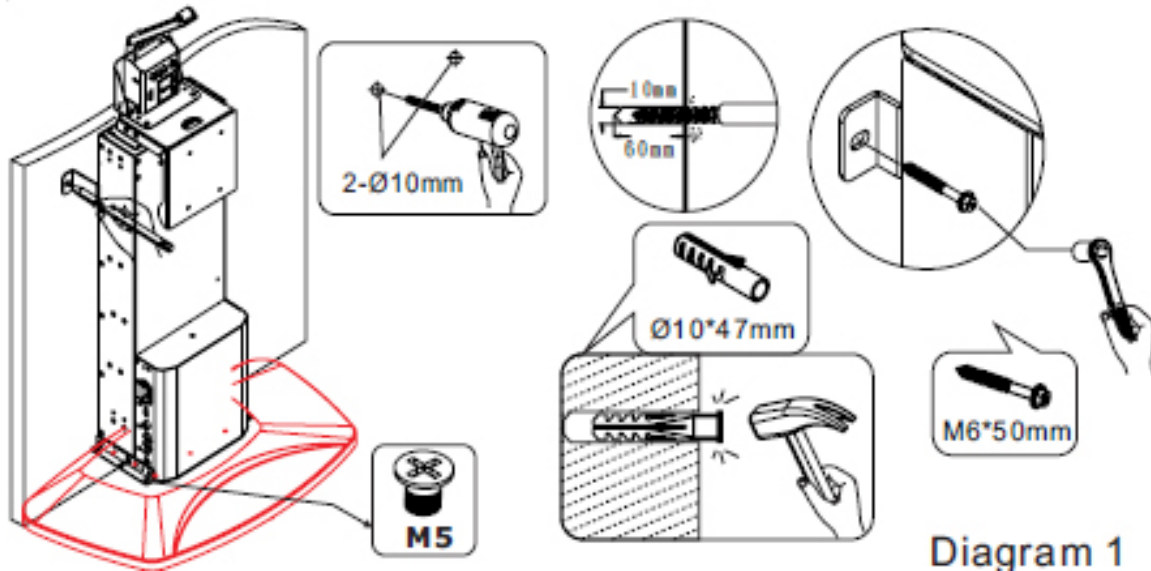

**B.** Then screw up the locking plate bracket to locking plate by 4pc (3)  $M6 \times 10\text{mm}$  Flat Head Screw. Insert two square tubes to the hole of locking plate bracket, then screw up them by 2pcs (6) plastic head screw (Let the stamped lines on the square tubes close to the edge of locking plate bracket), hang TV brackets (2pcs) on the square tubes and tighten them by (4) 4pcs plastic head screws (Keep the distance between the two brackets same as the distance of the horizontal holes on TV back cover) (see diagram2)

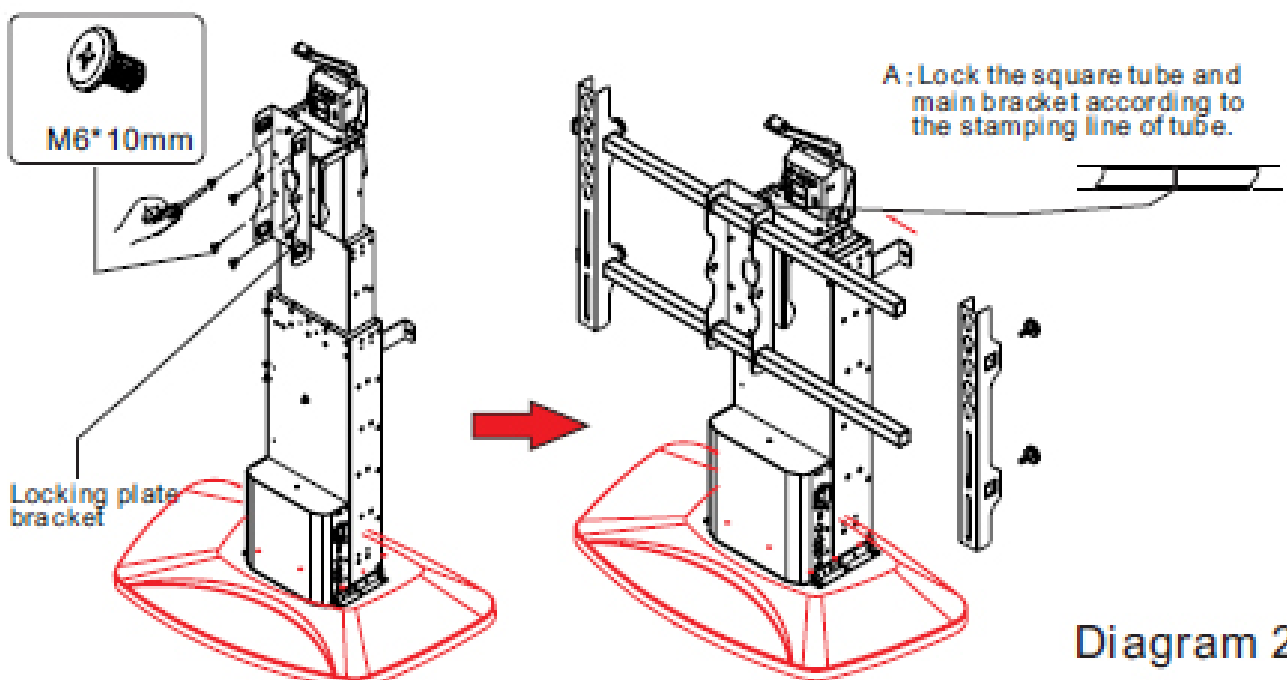

**C.** Screw up the 2pcs (8) tab to the upper holes of TV back cover by 2pcs (6) sink head screw, then hang TV to the corresponding holes of TV bracket by the two tabs. Put the 2pcs (9) pad between TV bracket and the holes on TV back cover, and then fasten them by 2pcs washer and 2pcs (7) M5/M6/M8 pan head screw. (See diagram 3)

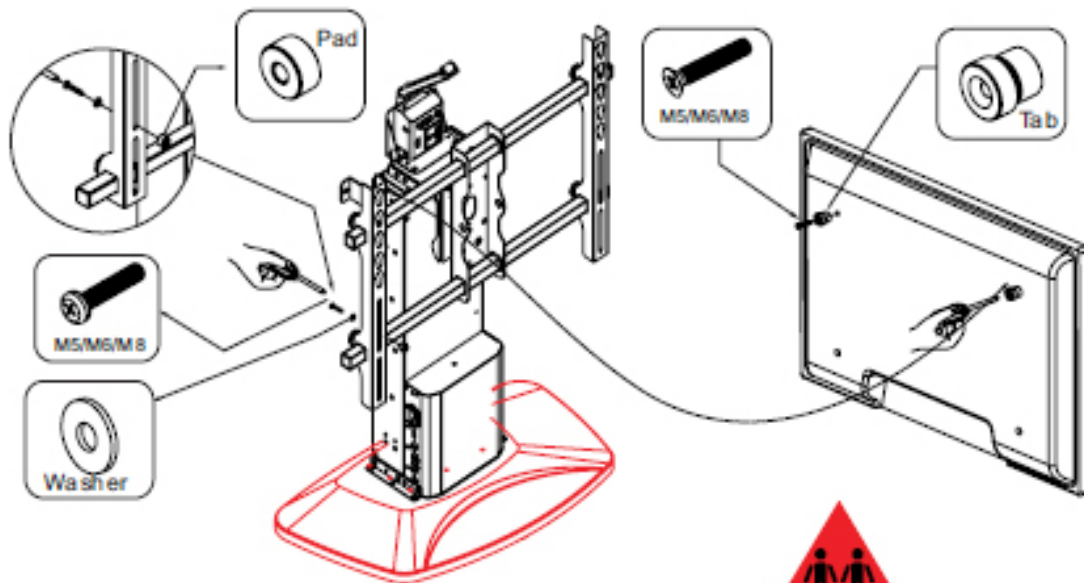
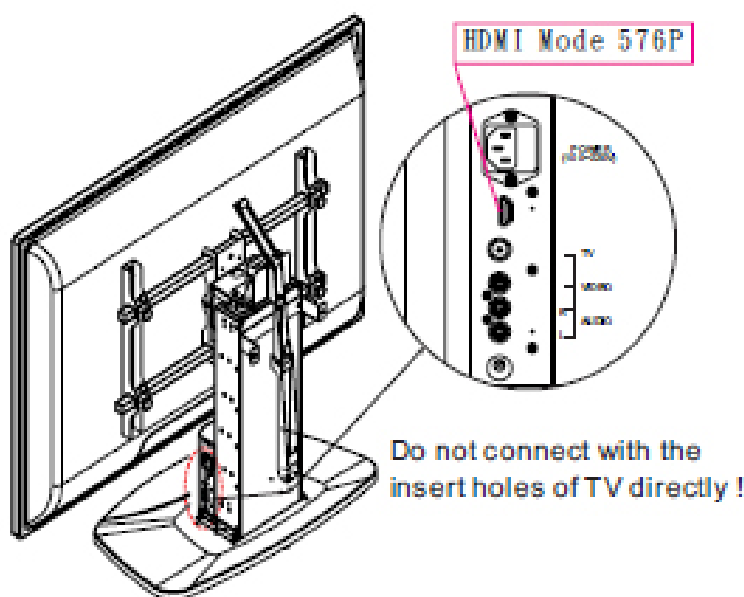

Diagram 3

**D.** After you make sure the installation is correct and fixedness, please connect the terminal of power, TV input signal, VIDEO and AUDIO input signal with base insert holes of post assembly. (Please comply with the installation instruction to connect strictly) (see diagram 4)



**Warning:**  
The base insert holes of post assembly is for power input, TV signal input, VIDEO and AUDIO signal input. The outside signal can be send to postassembly through it, do not connect with the inserts holes of TV directly. Please operate it strictly according to the installation instruction, otherwise manufacturer will not bear compensation and law obligation for any damage and safety problem.

Diagram 4

**E.** After finish and check above installation step, please connect terminal of power, TV signal, VIDEO and AUDIO signal of TV with top insert holes of post assembly. ( Please comply with the installation instruction to connect strictly) (See diagram 5)

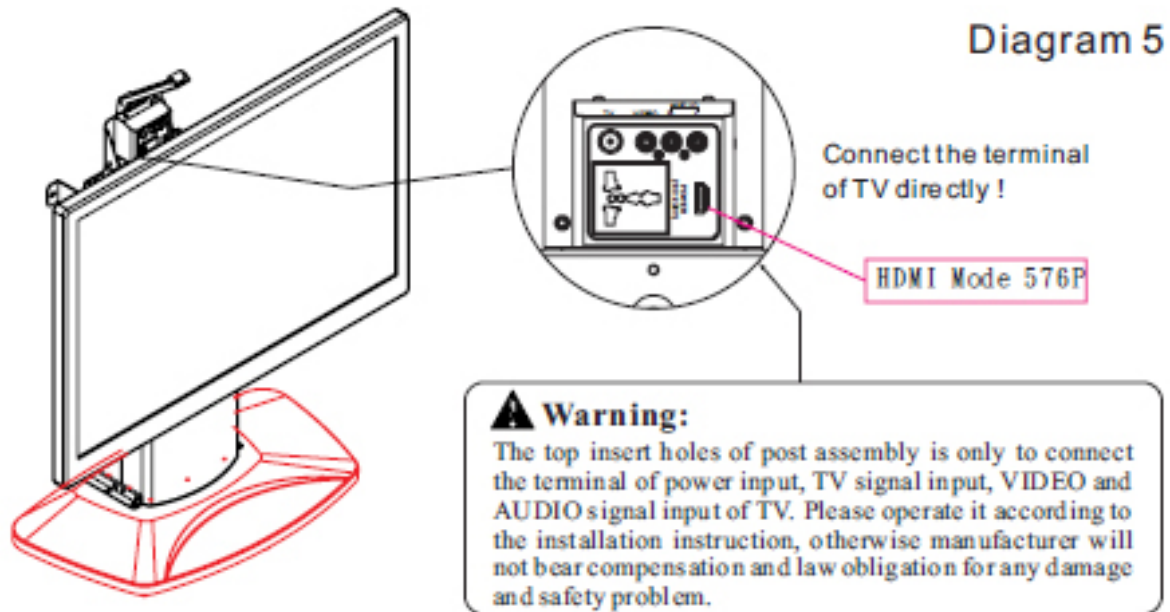

**F.** After ensure that the above step is ok, please insert the power of this product. (See diagram 6)

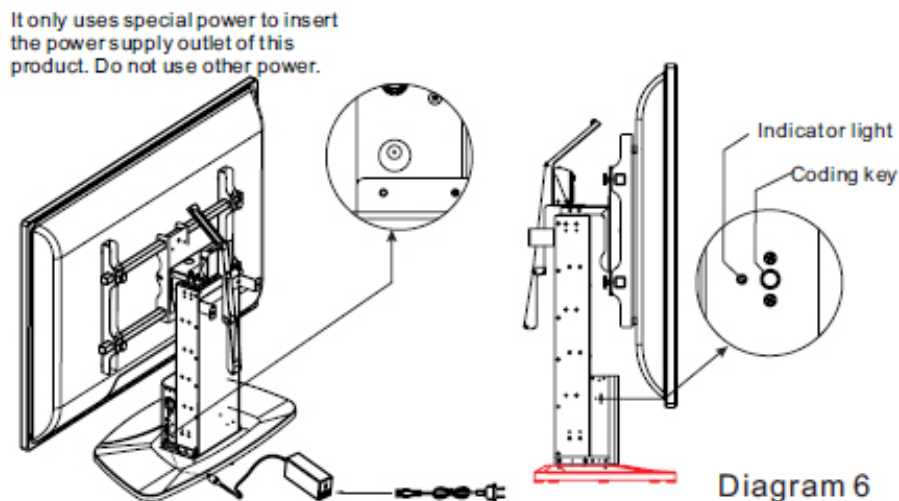

**G.** Using special remote control that attached to test this product. This lift mount is composed of three section, the max rising length is 860 mm, If the test result is ok, it means installation is finished. (see diagram 7)

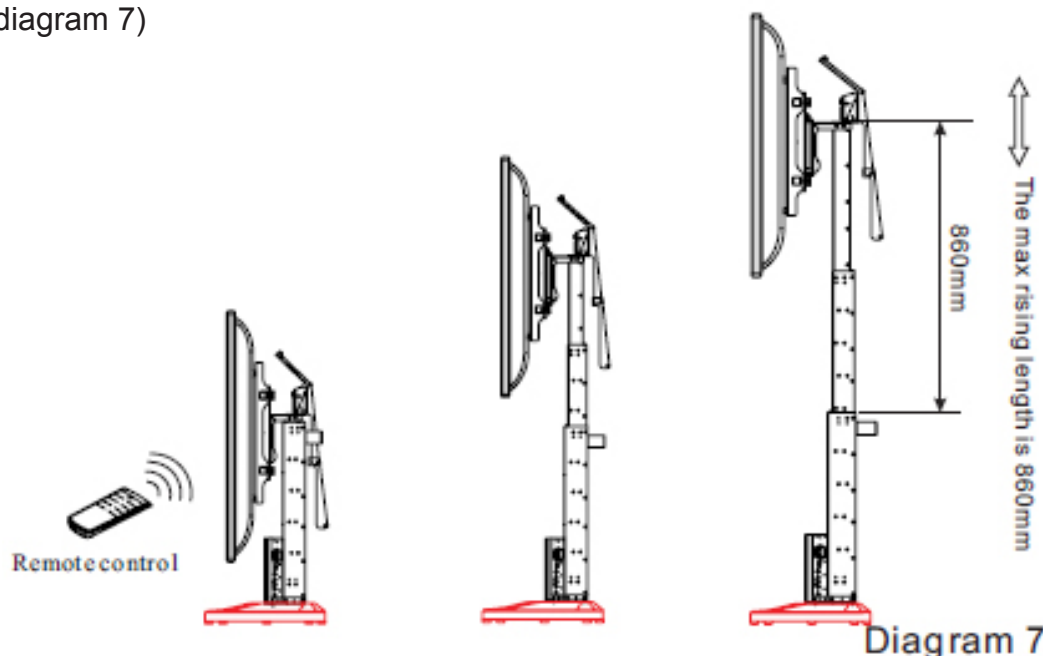

### 3-1. REMOTE CONTROL (See diagram 9):

#### A. KEY FUNCTION

1. Up : one push to extend elevating stand to the top.
2. Down : one push to back elevating stand to the bottom.
3. Left : hold on to raise elevating stand.
4. Right : hold on to lower elevating stand.

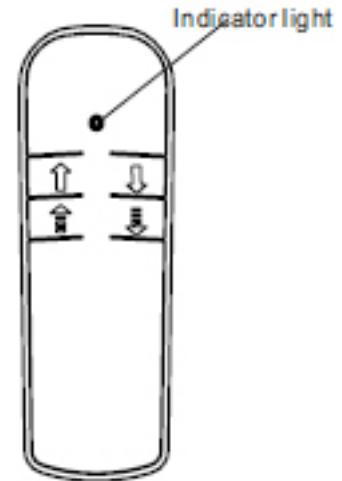

Diagram 9

#### B. OPERATING METHOD

1. Aim the remote control at TV to operate. The effective distance is within 10m.
2. This remote control matches one 23A12V battery. If the battery ran out, please open the battery cover to exchange new one.
3. When user press any function key of remote control, the TV bracket with TV will move to the corresponding place ,and will stop when you loosen the key.

#### C. NOTICE

If any remote control of our product was lost or damaged, you can buy a new remote control with the same frequency which produced by our company and do following operation:

1. Memory cleaning: pressing coding key about 10 seconds, the memory will be cleaned after the indicator closed. (The memory is the coding memory of the previous remote control)
2. Use new remote control: pressing any key of remote control and the coding key 1-2 seconds at the same time, loosening remote control firstly, then loosen the coding key, finally, you can operate the product with new remote control. (Coding key, Indicator, Please see diagram 6)

### 3.2. TECHNICAL PARAMETERS:

Item Model	TV Screen Size (inch)	Cart Dimension	Max Installation Size (inch)	Min Installation Size (inch)	Loading (lbs)	Extending Length(in)	Net Weight (lbs)
NY-16	32~42"	28"x 16"x 34"	24 x 16	8 x 8	110	34	

## WARNING:

This wall mount is intended for use only with the maximum weight indicated. Use with heavier than the maximum weight indicated may result in instability causing possible injury.

### 3.4. CAUTION:

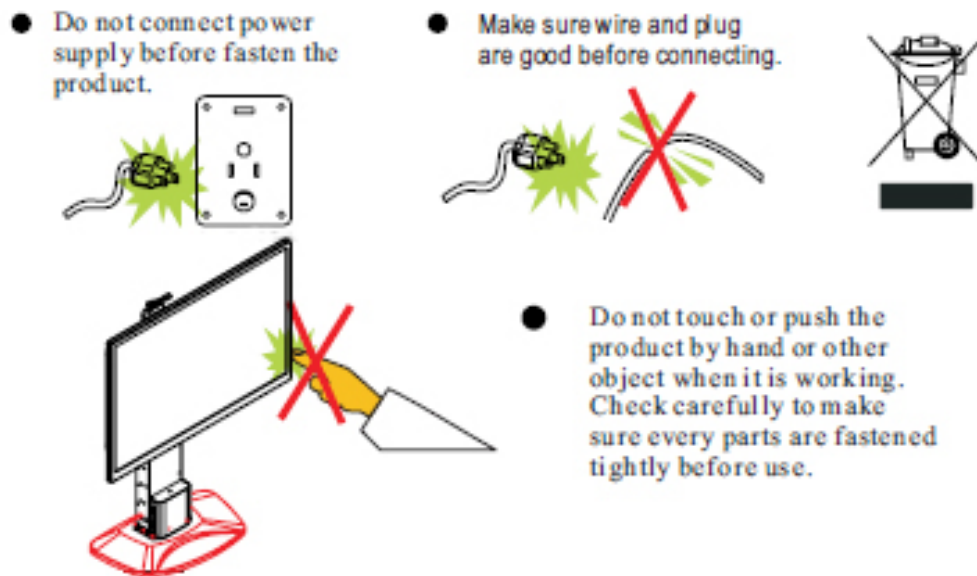

### 3.5. Maintenance

Often to check the product, ensure the safety. Do not use corrosive agent or alcohol or chemical cloth to clean.

4. Reliability Temperature and humidity condition: -20 C - +50 C, 80%HR

## WARNING:

1. Do not disassemble the product to repair by yourself. Warranty for electricity is void after disassembled!
2. After you installed the apparatus, please check the expansion screws and all fastening devices every 3 months, and please do not use it and contact the local dealer if gets loose, rusty or lost.
3. The apparatus should not be exposed to tripping or splashing water. Objects filled with liquids, such as vases, should not be placed on the apparatus.
4. Please not adjust the TV stand optional after adjust it on the proper position.