



1. SPECIFICATION

1-1. DIMENSION







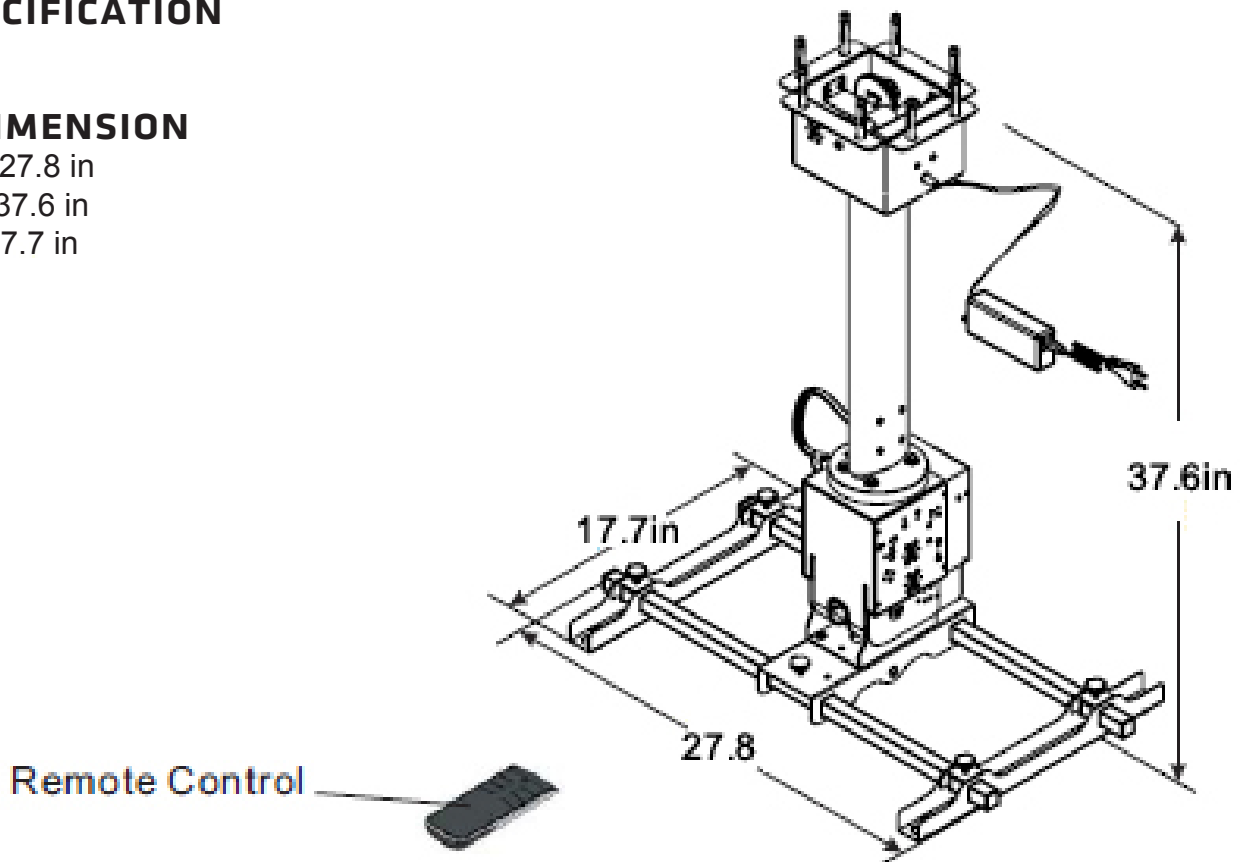

Length: 27.8 in

Height: 37.6 in





Width: 17.7 in



1-2. INSTALLATION PARTS:

①	2pcs	②	2pcs	③	2pcs	④	2pcs	⑤	2pcs
	Sink head screw M5/M6/M8(mm)		Tab M5/M6/M8(mm)		Round head screw M5/M6/M8 (mm)		Washer ø18*8.2*T1.5/ ø18*8.4*T1.8(mm)		Pad M5/M6/M8 (mm)
⑥	8pcs	⑦	6pcs	⑧	1 pcs	NOTICE 1: Use originals only, any other unapproved components may result in the falling off of TV and this bracket.			
	M8*70mm Expansion screw		M6*18mm Round head screw		Remote control	NOTICE 2: Check all the parts as shown on the manual included. If parts are missed or damaged, do not use it and please return to your local distributor.			

1.3 ASSEMBLY TOOLS (NOT INCLUDED)

				
14MM Wrench	Cross screwdriver	11MM Pecussion borer	Hammer	Pencil

2. ELECTRIC SPECIFICATION

2-1. INPUT VOLTAGE/CURRENT/FREQUENCY:

100-240VAC, 1.2A,50/60Hz

Output Current: DC24V ,3A

2-2. MOTOR

Motor	Rated Voltage	Current (No load)	Current (Rated load)	Operation Temperature
DN3435-3046E	DC24V	≤ 0.5 A	≤ 2 A	-20 C ~ -50 C
PR545AG-12300-IG32-721	DC24V	≤ 0.3 A	≤ 0.5 A	-20 C ~ -50 C

WARNING:

1. Incorrect installation may result in fall off of TV and this bracket and personal injuries.
2. Ceiling mounting of this bracket is out of the responsibility of manufacturer shall be carried out by competent persons, or licensed person, with using the attached anchors (Ø10-M8x70) only to ensure the safety.
3. Use this bracket properly, please read the instructions carefully before installation. Keep this guide well for further reference.
4. The user must pay attention to the weight of TV and This product, and only solid wall (the wall must be make up of concrete or brick) can support the weight . Please complied with the installation instruction of LCD/PDP to install them.
5. Do not attach the TV on the bracket before installations.

3. INSTALLATION INSTRUCTION

3-1. Firstly,please make sure the wall thickness for TV wall mount is at least 80mm and the position where you want to install the TV do not have any rigid materials(such as : reinforcing steel bar , steel block ,etc) and any loose phenomena. Make the mark at the place of ceiling that you want to mount the TV.Use percussion borer to drill 8 holes on the mark,at Φ10mm and 70 depth. Take out 8 pcs (6) expansion screws from the fitting bag,insert them through the holes of cart into the hole of ceiling by hammer and fasten them by wrench. (See diagram 1)

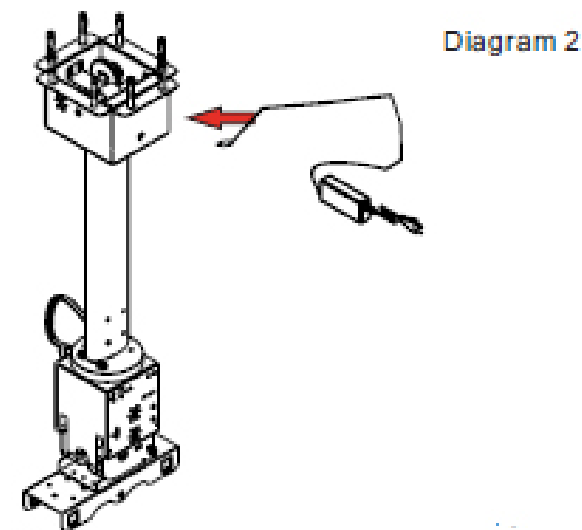
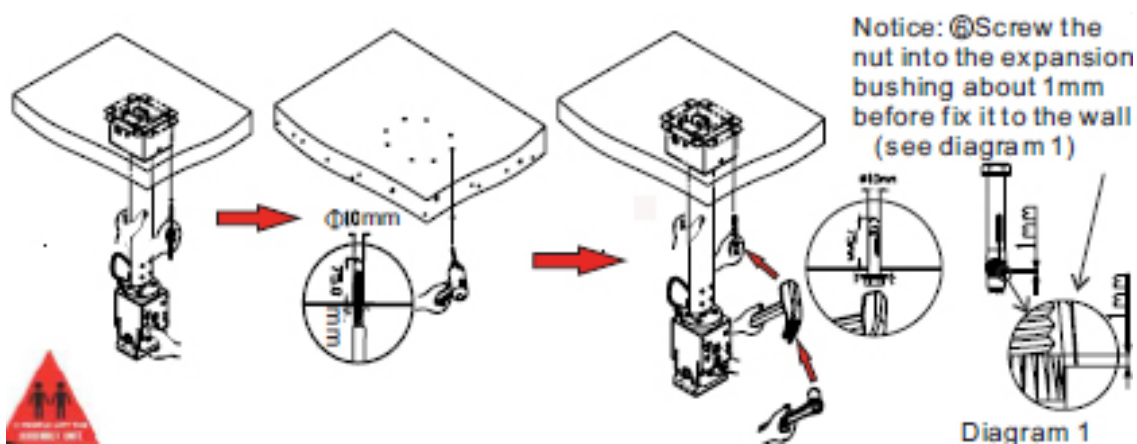

3-2. Take out the power plug from carton Insert one end to TV cart and other end to power supply. (see diagram 2)

NOTE:

Please fasten the power plug or placed it to appropriate place

3-3. Connect power and press "Down" key on the remote control to let the cart pitch to horizontal position. Insert square tube into conjunctive bracket and fasten them by (7) round head screw. Hang TV bracket on square tube and fasten by (7) round head screw. (see diagram 3)

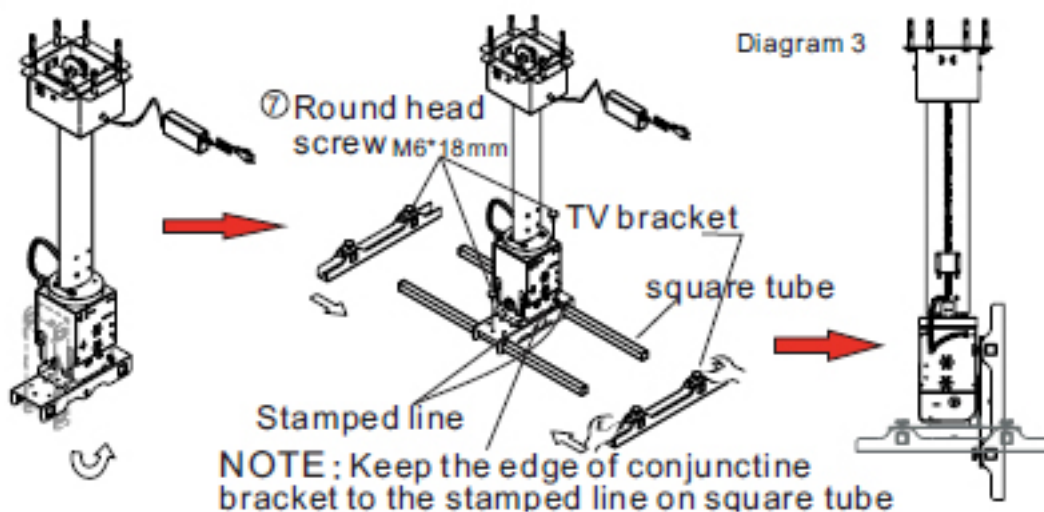

3-4. Fasten (2) tab on the upper end of TV back panel by (1) sink head screw. Check fastness, then hook TV on the cart's TV bracket. (see the diagram 4)

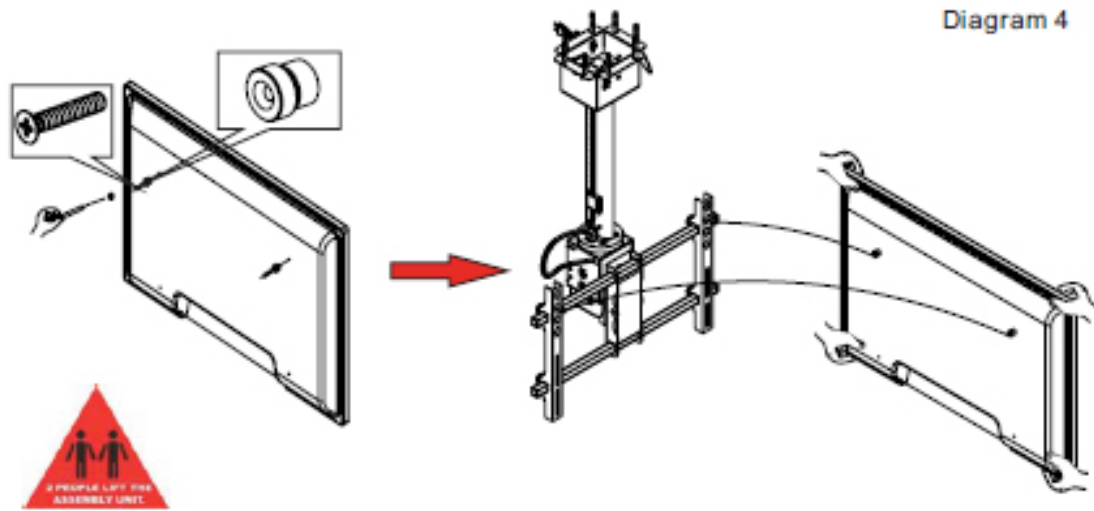

3-5. Through (4) washer and slot of TV bracket and (5) pad, (3) pan head screw fasten the down side of TV. (5) Pad should be placed between TV bracket and TV. (see the diagram 5)

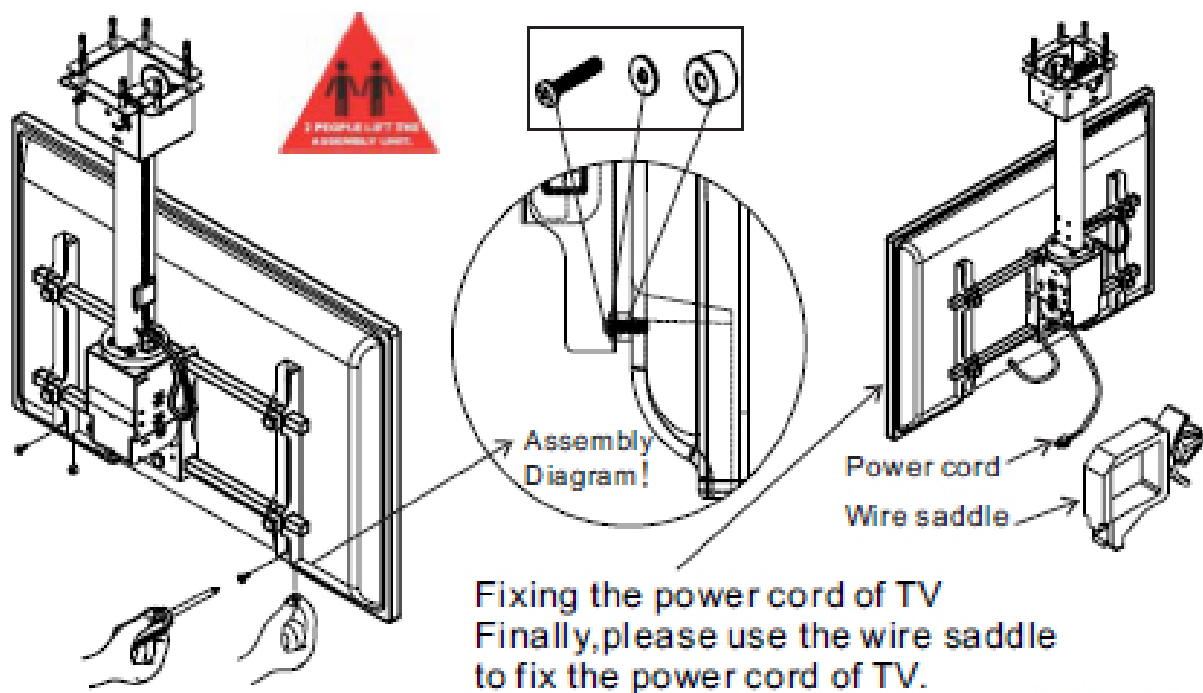

4. OPERATING INSTRUCTION.

4-1. FUNCTION

Using remote control can turn TV left or right to angel 35 and pitch up or down to 87 angel (vertical or horizontal), lower length is 350 mm. (See a;b;c diagrams)

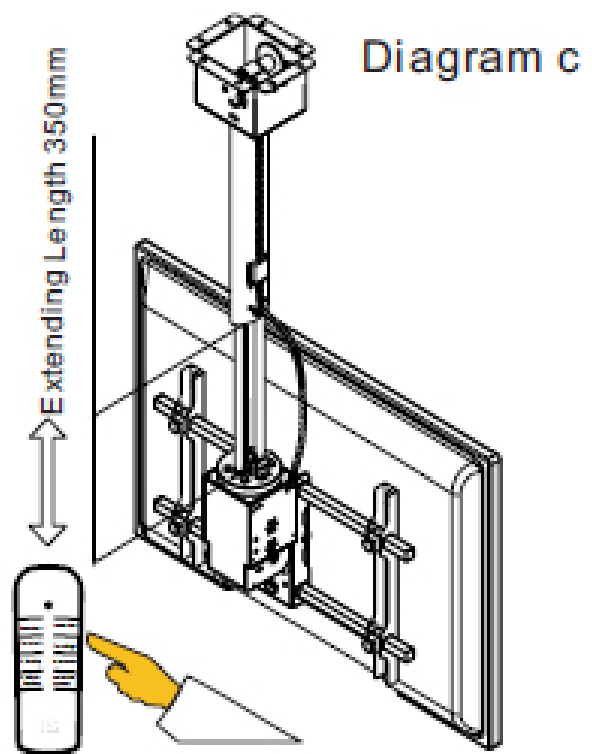
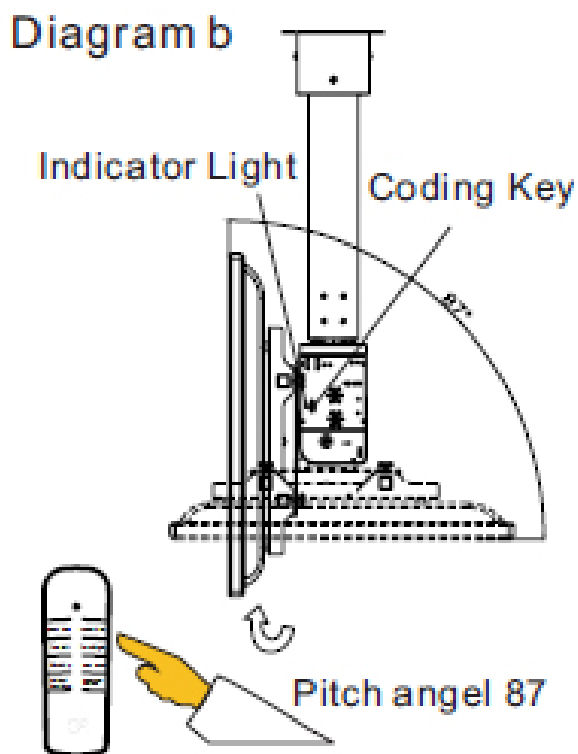
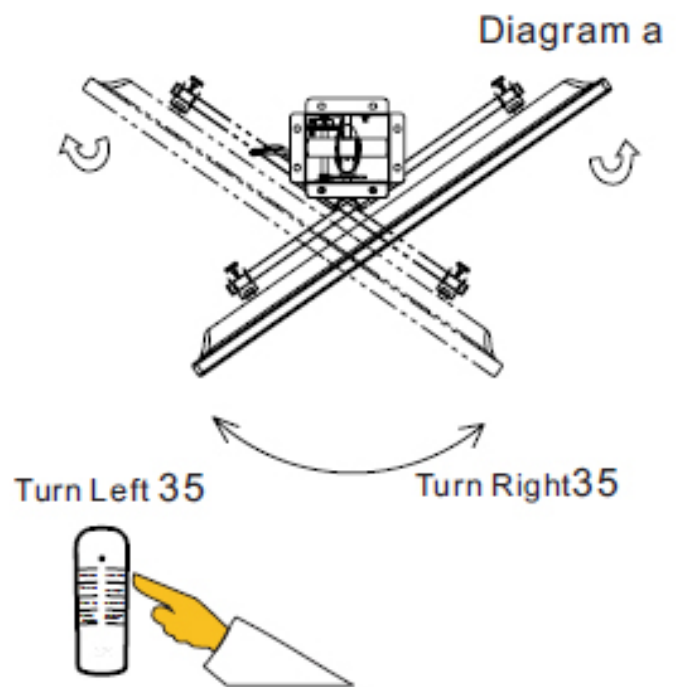

4. TECHNICAL PARAMETERS:

Item Model	TV Screen Size (inch)	Cart Dimension	Max Installation Size (inch)	Min Installation Size (inch)	Loading (lbs)	L/R angle (°)	Extending Length(in)	Net Weight (lbs)
NY-21	32~42"	27.8"x 17.7"x 37.6"	23.6 x 15.7	7.9 x 7.9	110.2	± 35	0~13.8	50.3 ±0.5

WARNING:

This ceiling mount is intended for indoor use only with the maximum weights indicated ,Use with heavier than the maximum weights indicated may result in instability causing possible injury!

5.2. REMOTE CONTROL (See diagram 6):

5-2.1. KEY FUNCTION

1. LEFT: Hold on to turn TV left
2. RIGHT: Hold on to turn TV right
3. UP: Hold on to tilt TV up
4. DOWN: Hold on to tilt TV down

ON: One push to extend cart to the programmed operating position automatic all. (Vertical position)

OFF: One push to back cart to the programmed storage position automatically. (Horizontal position)

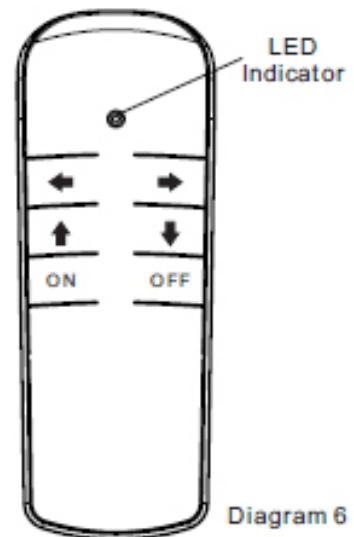

Diagram 6

5-2.2. OPERATION INSTRUCTION

1. Aim the LED indicator on remote control at TV. The remote range is 3-10m.
2. When you press one of the function key on remote control straightly (raise, lower, left, right, up, down) the mount will move to the direction you expected. Loosening, the mount will stop.
3. Insert one 23A, 12V battery in the remote control. If the battery ran out, please open the back cover of the remote control and put in the new one.

5-2.3. NOTICE:

If any remote control of our product was lost or damaged, you can buy a new remote control with the same frequency which produced by our company and do following operation:

1. Memory cleaning: pressing coding key about 10 seconds, the memory will be cleaned after the indicator closed. (The memory is the coding memory of the previous remote control)
2. Use new remote control: pressing any key of remote control and the coding key 1-2 seconds at the same time, loosening remote control firstly, then loosen the coding key, finally, you can operate the product with new remote control. (Coding key, Indicator, Please see diagram b)

6. CAUTION:

- Do not connect before fasten the product.



- Make sure wire and plug are good before connecting.

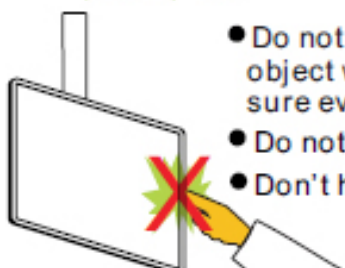
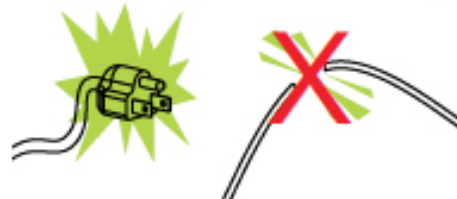

- Do not touch or push the product by hand or other object when it is working. Check carefully to make sure every parts are fastened tightly before use.
- Do not use outdoors unless marked for outdoor use.
- Don't hang other weights on this bracket!

7. MAINTENANCE

Unplug the powers of this bracket& FPD before maintenance is engaged in and follow the instructions described in FPD 's manual for daily maintenance of TV& bracket. Do not use corrosive agent or alcohol or chemical cloth to clean!

4. RELIABILITY

Temperature and humidity condition: -20 C - +50 C, 80%HR

WARNING:

1. Do not disassemble the product to repair by yourself. Warranty for electricity is void after disassembled!
2. After you installed the apparatus, please check the expansion screws and all fastening devices every 3 months, and please do not use it and contact the local dealer if gets loose, rusty or lost.
3. The drive component of this product is uncontinual drive component. If need to work continually, you must stop 2 hours after working 8 hours!
4. This appliance is not intended for use by persons (including children) with reduced physical, sensory or mental capabilities, or lack of experience and knowledge, unless they have been given supervision or instruction concerning use of the appliance by a person responsible for their safety.
5. Children should be supervised to ensure that they do not play with the appliance.

HINT OF HOW TO DISPOSE:

- Do not dispose of electrical appliances as unsorted municipal waste, use separate collection facilities.
- Contact your local government for information regarding the collection systems available.
- If electrical appliances are disposed of in landfills or dumps, hazardous substances can leak into the groundwater and get into the food chain, damaging your health and well-being.
- When replacing old appliances with new once, the retailer is legally obligated to take back your old appliance for disposal at least for free of charge.

